AE-341 SERIES PROCESS INDICATORS

2 TO 6 DIGITS

0-20 MA, 4-20 MA, 0-5V, OR 0-10V SCALED INPUT

AE-341 SERIES PROCESS INDICATORS - 2 TO 6 DIGITS
REV 09/18/00

DESCRIPTION

AE Series Process Indicators are available with 1", 2.3", 4", 8", or 12" high digits, visible from 5 feet to 500 feet away. They are available in 2, 3, 4, 5, and 6 digit versions. Standard input signals include 0-20 MA, 4-20 MA, 0-5 VDC, and 10 VDC. They can be programmed to indicate any engineering units over the range of the analog input signal using the built-in programming switches. AE Series Process Indicators have a 12-bit A/D converter that can resolve up to four digits. On five or six digit versions the least significant digits can be fixed to 00. Degrees F and C indicators can also be displayed.

This manual covers all AE Series displays from two digits to six digits, including two-sided versions with the Analog Input option (341) installed. It will use the term "the AE DEVICE", in some cases to cover all versions of displays.

The model numbers of the AE-341 Series are derived from the digit size and the number of digits in the display, followed by the 341 suffix. For example the AE24-341 is 2.3 inch, four-digit display and the AE126-341 is a twelve inch six digit display. For two-sided versions, the model number would have /2. For example: AE84/2-341 would be the model number for a Two-Sided, Eight Inch, Four Digit Process Indicator. Each AE Display can be configured in a number of ways. Some will have different enclosures. For more information on your specific model number refer to the drawings included at the back of this manual.

Other features include +/- range scaling, over-range and under-range indication, selectable decimal point and leading zero blanking.

For multiple display system the Master/Driver Option (348) can be added. This option allows you to connect up to 40 remote displays to the AE Series Process Indicator for displaying the same variable in many locations.

For other types of input signals, such as Thermocouple or MV signals, specific signal conditioners can be used. Contact the factory for more details.

There are a variety of hardware configurations available including wall mount, rack mount, two sided wall or ceiling mount, and NEMA type enclosures for all applications. For your specific model number and hardware configuration refer to the drawings at the back of this manual.

AE-341 SERIES PROCESS INDICATORS - 2 TO 6 DIGITS
REV 09/18/00

SPECIFICATIONS

Digits: 1, 2.3, 4, 8 and 12 Inch High, Seven Segment Digits are available. For additional digit specifications, see the drawings at the back of this manual for your specific model.

Number of Digits: Models range from 2 to 6 digits with a 4 digit maximum resolution. On 5 and 6 digit versions they are fixed as 0's or as degrees F or degrees C indicators. See the drawings at the back of this manual for your specific model.

Analog Input: 0-20 MA DC, 4 - 20 MA DC, 0-5VDC, or 0-10VDC. Specify with order.

Resolution: 12 bit A/D Converter (4096 COUNTS).

0-20 MA	4.88 UA
4-20 MA	4.88 UA
0-5 VDC	1.22 MV
0-10 VDC	2.44 MV

Range: Programmable from 000000 to 999900 or -99990 to 99990 for +/- configuration (factory configured), depends on the number of digits. Range limits are stored in non-volatile memory. Built-in switches are provided on the PCB assembly for programming the range.

Decimal Point:
and Leading
Zero Blanking: Switch selectable on PCB assembly.

Power: 120 VAC – The power required varies with the size and number of digits. Optional power includes 50 HZ, 12 VAC, 15 VDC and 220 VAC.

Operating
Temperature: 0 to 50 Degrees C.

Enclosure: Black anodized aluminum with .118" thick red acrylic lens. The back panel is .125" thick black, ABS plastic. The size varies with the size and number of digits. See the drawings at the back of this manual.

A 1210-0101 mounting bracket is provided for wall mounting to a single or double gang box. Optional enclosures are available.

Wiring: Clearly labeled, pigtail lead wires (#18 AWG) are provided. Optional terminal blocks, power cords, and connectors are available.

For all other options refer to the drawings at the back of this manual for additional specifications.

AE-341 SERIES PROCESS INDICATORS - 2 TO 6 DIGITS
REV 09/18/00

INSTALLATION

MOUNTING

The AE Series Displays can be mounted in a variety of ways. Things to consider for mounting include ambient light, viewing area, ambient temperature, dirt or dust. Most models are supplied with one or more 1210-0101 mounting brackets for wall mounting to a single or double gang box. See the detail below. For other mounting options, such as eyebolts, refer to the specific drawings.

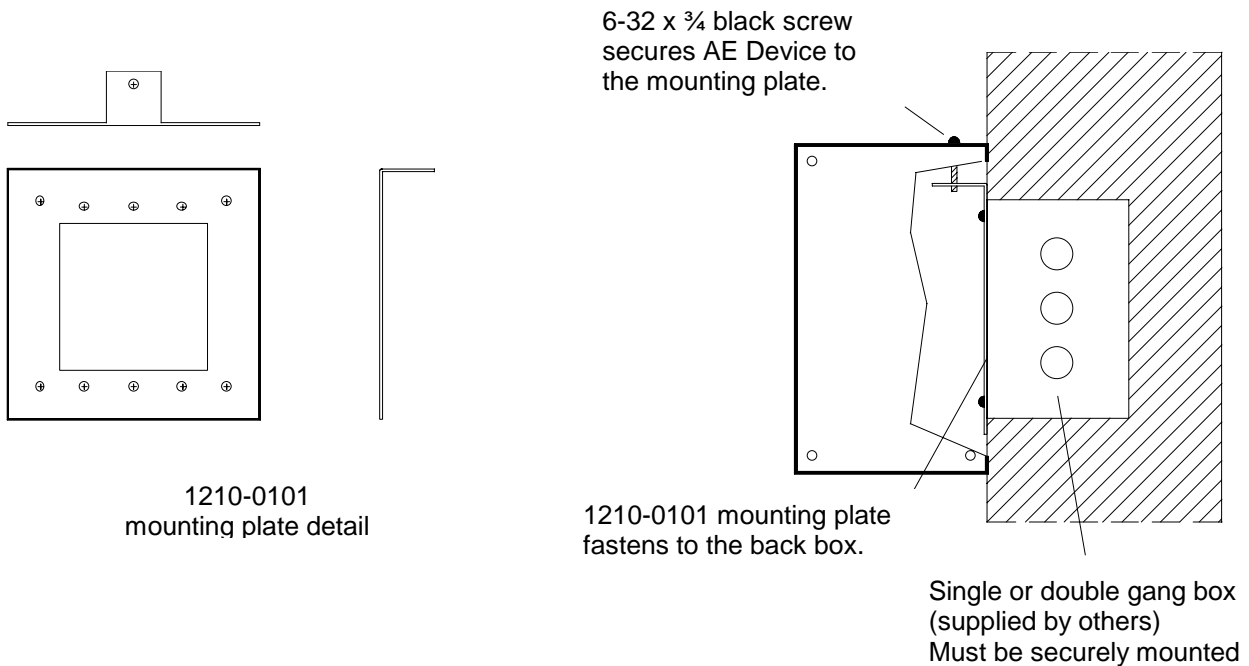

WIRING

Field wiring will depend on the specific hardware configuration. On most units the AC power has been pre-wired and clearly labeled pigtail leads are provided at the back panel for termination in single or double gang box as shown above. Some models come with AC power cords or 12 VAC power modules. These can be plugged into a standard 120 VAC outlet. For any other power configurations, refer to the specific wiring diagrams provided.

The analog signal input is also pre-wired on most units. Labeled wires (WH/RED +, WH/BLK -) are provided at the back panel for termination in single or double gang box as shown above. On units supplied with a shielded cable pigtail for the analog signal, the colors could be (WHITE + and BLACK -). Be sure to follow all local wiring codes.

On double sided units, the wiring can be specified for top, bottom or side conduit fittings.

SETTINGS AND CONTROLS

On most displays the switches and controls for setting the leading zero blanking and for calibration are located on the PCB assembly. To gain access to these controls, remove one of the side and slide out the back panel. Once the back panel is removed, the controls are easily accessed. On double sided units, the calibration controls, only, are located on the top panel of the display.

SETTING LEADING ZERO BLANKING AND THE DECIMAL POINT LOCATION

Access to the AEXX Controller is required to make the following adjustments. Refer to the above section or to the specific drawings at the back of this manual.

The leading zero blanking and decimal point have been set to the off position on all AE Series Displays, unless specified otherwise by your order. A rotary selector switch located on the AEXX CPU/DRIVER PCB assembly has been pre-set at the factory. To select leading zero blanking and/or to display the decimal point, rotate the selector switch to the desired location as listed in the table below:

POSITION 0	NO BLANKING, NO DP	(000000) - (050000) - (100000)
POSITION 1	NO BLANKING, DP	(0.00000) - (0.50000) - (1.00000)
POSITION 2	NO BLANKING, DP	(00.0000) - (05.0000) - (10.0000)
POSITION 3	NO BLANKING, DP	(000.000) - (050.000) - (100.000)
POSITION 4	NO BLANKING, DP	(0000.00) - (0500.00) - (1000.00)
POSITION 5	NO BLANKING, DP	(00000.0) - (05000.0) - (10000.0)
POSITION 6	NO BLANKING, DP	(000000.) - (050000.) - (100000.)
POSITION 7	NO BLANKING, NO DP	(000000) - (050000) - (100000)
POSITION 8	BLANKING, NO DP	(000) - (50000) - (100000)
POSITION 9	BLANKING, DP	(. 000) - (.50000) - (1.00000)
POSITION A	BLANKING, DP	(. 000) - (5.0000) - (10.0000)
POSITION B	BLANKING, DP	(. 000) - (50.000) - (100.000)
POSITION C	BLANKING, DP	(0.00) - (500.00) - (1000.00)
POSITION D	BLANKING, DP	(00.0) - (5000.0) - (10000.0)
POSITION E	BLANKING, DP	(000.) - (50000.) - (100000.)
POSITION F	BLANKING, NO DP	(000) - (50000) - (100000)

The table is for a six-digit display. This varies depending on the number of digits.

Leading zero blanking is not recommended for +/- scaled ranges.

SETTING THE “F” AND “C” INDICATORS

This function is usually set at the factory. However, for temperature display applications, 6 digit versions can be set for °F or °C indication.

To set the display for °F indication, jumper S3 (“down”) to GND. To set the display for °C indication, jumper S4 (“up”) to GND. Units configured for positive readings only will display °F or °C. For +/- configured units, only the F or C will be displayed.

PROGRAMMING THE RANGE

The programmed range or calibration can be specified with your order. In this case it will be factory set to display your variable between the low and high limits, and for the type of analog input specified. The range can be changed, if desired, using the programming switches located on the PCB assembly. An accurate, adjustable 4 - 20 MA current source, or 0-10 VDC voltage source will be required.

To change the range, the lower and upper limits of the range need to be re-programmed. Connect the 4 - 20 MA, or 0-10 VDC calibration source to the analog input depending on the input required by your specific model.

For +/- scaled ranges the "Lo" (lower limit) will always be assigned a negative value.

0-20 or 4-20 MA CALIBRATION

If you are using a 0-20 MA signal, substitute a 0 for the 4 in the instructions below.

To set the lower limit, set the current source to 4 MA. Set the SET/RUN switch located on the PCB assembly to the SET position. The display will be flashing "Lo". Press the ENT push button. The display will show up to 4 numbers, depending on your model. The first digit will be flashing. Press the INC switch until the desired first digit is shown, then press ENT. The second digit will now be flashing. Press the INC switch until the desired second digit is shown, then press ENT. Repeat this procedure for the remaining third and fourth digits. After entering the fourth digit the display will show *done*. If your display has less than four digits, press ENT until the display shows *done*. Set the SET/RUN switch back to the RUN position. The new value will be shown on the display. If "Err" is shown, this means the lower limit is higher than the upper limit. This is not a problem as long as the upper limit is re-programmed to a new value greater than the lower limit.

To set the upper limit of the range, set the current source to 20 MA. Set the SET/RUN switch to the SET position. The display will be flashing "Lo". Press the INC switch until the display flashes "Hi", then press ENT. Again, the display will show up to 4 digits. The first digit will be flashing. Using the INC and ENT switches, enter the 4 digits for the upper limit in the same manner as the lower limit digits were entered. After entering the fourth digit, the display will show *done*. If your display has less than four digits, press ENT until the display shows *done*. Set the SET/RUN switch back to the RUN position. The display will show the new upper limit value. If "Err" is displayed this means your upper limit is lower than the lower limit and you will have to re-program the limits.

Once the range limits have been programmed, the display will indicate a linear response to the 4 - 20 MA DC signal between the programmed limits.

Before re-assembling the unit be sure the SET/RUN switch is in the RUN position.

0-5 VDC OR 0-10 VDC CALIBRATION

To set the lower limit, set the voltage source to 0 VDC. Set the SET/RUN switch located on the PCB assembly to the SET position. The display will be flashing "Lo". Press the ENT push button. The display will show up to 4 numbers. The first digit will be flashing. Press the INC switch until the desired first digit is shown, then press ENT. The second digit will now be flashing. Press the INC switch until the desired second digit is shown, then press ENT. Repeat this procedure for the third and fourth digits. After entering the fourth digit the display will show *done*. If your display has less than four digits, press ENT until the display shows *done*. Set the SET/RUN switch back to the RUN position. The new value will be shown on the display. If "Err" is shown, this means the lower limit is higher than the upper limit. This is not a problem as long as the upper limit is re-programmed to a new value greater than the lower limit.

AE-341 SERIES PROCESS INDICATORS - 2 TO 6 DIGITS
REV 09/18/00

To set the upper limit of the range, set the voltage source to 5 VDC or 10 VDC depending on the input range of your model. Set the SET/RUN switch to the SET position. The display will be flashing "Lo". Press the INC switch until the display flashes "Hi", then press ENT. The display will show up to 4 digits. The first digit will be flashing. Using the INC and ENT switches, enter the 4 digits for the upper limit in the same manner as the lower limit digits were entered. After entering the fourth digit, the display will show *done*. If your display has less than four digits, press ENT until the display shows *done*. Set the SET/RUN switch back to the RUN position. The display will show the new upper limit value. If "Err" is displayed this means your upper limit is lower than the lower limit and you will have to re-program the limits.

Once the range limits have been programmed, the display will indicate a linear response to the 0 -5 VDC or 0-10 VDC signal between the programmed limits.

Before re-assembling the unit be sure the SET/RUN switch is in the RUN position.

+/- SCALED RANGE

If your unit is configured for a +/- scaled range then the display is programmable from -9999 to 9999. The left most digit will always be reserved for the minus sign. A positive sign will not be displayed but the left most digit will remain blank for any positive input values. The display will provide up to four digits of resolution and one fixed zero on the right most digit which can also be set to display an "F" or "C" if desired.

When using leading zero blanking the minus sign will remain to the immediate left of the most significant digit as the number may become a lesser value. Leading zero blanking is not recommended for +/- scaled ranges.

The calibration procedure remains the same as the standard unit. Note however that when setting the lower limit the display will not show a negative sign even though any lower limit value which is set will be assigned a negative value.

OPERATION

After all wiring and installation is complete, the unit can be powered on.

Apply power to the unit. The displays will rotate during the power on self-test and then a version number will appear for a few seconds. Then the AE-341 display will show the input signal value.

TECHNICAL SUPPORT

For any questions concerning installation and operation of this product, contact our factory at:

PHONE (800) 444-7161
OR
FAX (318) 797-4864

SERVICE POLICY

It is recommended that all service for this product be done by the factory or by a factory authorized service representative. Applied Technical Systems will provide ongoing service support in and out of warranty. Send your repairs to:

APPLIED TECHNICAL SYSTEMS
849 KING PLACE
SHREVEPORT, LA 71115

APPLIED TECHNICAL SYSTEMS
WARRANTY POLICY

ATS warrants its products to be free of defects in material and workmanship for a period of 24 months from the date of purchase. ATS will repair or replace any product returned to its authorized factory service center within the warranty period so long as there is no evidence that the product has been abused, misused, damaged by lightning, overloads of any kind or water, or altered in any way.

Products returned for warranty must be returned with freight prepaid. ATS will pay normal freight charges to return the product to the customer. Special premium freight requested by the customer will be charged to the customer.

ATS disclaims any warranties expressed or implied, including merchantability and/or fitness for a particular purpose. In no event shall ATS be held liable for incidental or consequential damages.